

CME Article

How I treat essential thrombocythemia

Elisa Rumi^{1,2} and Mario Cazzola^{1,2}¹Department of Hematology Oncology, Fondazione Istituto di Ricovero e Cura a Carattere Scientifico Policlinico S. Matteo, Pavia, Italy; and ²Department of Molecular Medicine, University of Pavia, Pavia, Italy

Essential thrombocythemia (ET) is an indolent myeloproliferative neoplasm that may be complicated by vascular events, including both thrombosis and bleeding. This disorder may also transform into more aggressive myeloid neoplasms, in particular into myelofibrosis. The identification of somatic mutations of *JAK2*, *CALR*, or *MPL*, found in about 90% of patients, has considerably improved the diagnostic approach to this disorder. Genomic profiling also holds the potential

to improve prognostication and, more generally, clinical decision-making because the different driver mutations are associated with distinct clinical features. Prevention of vascular events has been so far the main objective of therapy, and continues to be extremely important in the management of patients with ET. Low-dose aspirin and cytoreductive drugs can be administered to this purpose, with cytoreductive treatment being primarily given to patients at high risk of vascular

complications. Currently used cytoreductive drugs include hydroxyurea, mainly used in older patients, and interferon α , primarily given to younger patients. There is a need for disease-modifying drugs that can eradicate clonal hematopoiesis and/or prevent progression to more aggressive myeloid neoplasms, especially in younger patients. In this article, we use a case-based discussion format to illustrate our approach to diagnosis and treatment of ET. (*Blood*. 2016;128(20):2403-2414)

Medscape Continuing Medical Education online

This activity has been planned and implemented through the joint providership of Medscape, LLC and the American Society of Hematology.

Medscape, LLC is accredited by the Accreditation Council for Continuing Medical Education (ACCME), the Accreditation Council for Pharmacy Education (ACPE), and the American Nurses Credentialing Center (ANCC), to provide continuing education for the healthcare team.

Medscape, LLC designates this Journal-based CME activity for a maximum of 1.00 *AMA PRA Category 1 Credit(s)*TM. Physicians should claim only the credit commensurate with the extent of their participation in the activity.

All other clinicians completing this activity will be issued a certificate of participation. To participate in this journal CME activity: (1) review the learning objectives and author disclosures; (2) study the education content; (3) take the post-test with a 75% minimum passing score and complete the evaluation at <http://www.medscape.org/journal/blood>; and (4) view/print certificate. For CME questions, see page 2477.

Disclosures

Laurie Barclay, freelance writer and reviewer, Medscape, LLC, owns stock, stock options, or bonds from Pfizer. Editor Bob Löwenberg and the authors declare no competing financial interests.

Learning objectives

Upon completion of this activity, participants will be able to:

1. Based on the review provided in this paper, distinguish the diagnosis of essential thrombocythemia (ET).
2. Determine treatment of ET.
3. Evaluate the determination of individual patient risk as a guide to selecting therapy for ET.

Release date: November 17, 2016; Expiration date: November 17, 2017

Introduction

Essential thrombocythemia (ET) is one of the Philadelphia-negative classical myeloproliferative neoplasms (MPNs), a category of the World Health Organization (WHO) classification of tumors of hematopoietic and lymphoid tissues that also includes polycythemia vera (PV) and primary myelofibrosis (PMF).^{1,2} In the last few years,

there have been significant advances in our understanding of the genetic basis, pathophysiology, and clinical course of ET.³⁻²⁰ Our article aims to offer up-to-date information and guidance regarding diagnosis and treatment of ET patients. To provide directions in the therapeutic management of common or complex clinical situations of the disease,

Table 1. Clinical vignettes illustrating representative cases of ET or related myeloid neoplasms

	Description	Clinical presentation	Diagnostic approach	Therapeutic decision-making
Case 1	Typical asymptomatic, middle-age woman with incidental thrombocytosis and the <i>JAK2</i> (V617F) mutation (low-risk <i>JAK2</i> -mutant ET).	A 40-y-old woman was referred to us because a routine CBC showed: Hb, 13.9 g/dL; WBC count, $9.2 \times 10^9/L$; PLT count, $464 \times 10^9/L$. Physical examination was normal.	Body iron status was normal and CRP was below 1.0 mg/L. Testing for <i>BCR-ABL1</i> fusion gene was negative. <i>JAK2</i> (V617F) was detected on granulocyte DNA (5% mutant alleles). Bone marrow biopsy showed megakaryocyte proliferation with increased numbers of enlarged, mature megakaryocytes. Silver impregnation after Gomori showed single scattered reticulin fibers consistent with the appearance of the normal bone marrow.	Low-risk <i>JAK2</i> (V617F)-mutant ET was diagnosed, and the patient was given low-dose aspirin (100 mg per day).
Case 2	Young woman with incidental thrombocytosis, mild oral mucosal bleeding after tooth brushing, and type 1 <i>CALR</i> mutation (low-risk <i>CALR</i> -mutant ET with acquired von Willebrand syndrome).	A 24-y-old woman was referred to us for incidental thrombocytosis: a routine CBC showed: Hb, 13.1 g/dL; WBC count, $7.3 \times 10^9/L$; and PLT count, $1069 \times 10^9/L$. She complained of oral mucosal bleeding after tooth brushing and occasional dizziness.	As <i>JAK2</i> (V617F) mutation was absent, we sequenced <i>CALR</i> exon 9 and detected the type 1 mutation (c.1092_1143del, L367fs*46). Bone marrow biopsy was consistent with a diagnosis of ET.	As PLT count was $>1000 \times 10^9/L$ and there was a history of mucosal bleeding, we assessed von Willebrand factor: ristocetin cofactor activity was low (30%) whereas the antigen level was normal, indicating an acquired von Willebrand syndrome. We therefore decided not to use low-dose aspirin: a cytoreductive treatment with interferon α will be considered if PLT count increases further (to $\geq 1500 \times 10^9/L$) and/or bleeding becomes more severe.
Case 3	Middle-age woman with incidental thrombocytosis and the <i>JAK2</i> (V617F) mutation who later also developed erythrocytosis (<i>JAK2</i> -mutant ET progressing to PV).	A 48-y-old woman was referred to us because a routine CBC count showed isolated thrombocytosis: Hb, 13.9 g/dL; Hct, 43.0%; MCV, 85 fL; WBC count, $9.5 \times 10^9/L$; and PLT count, $838 \times 10^9/L$. She was asymptomatic and the spleen was not palpable.	<i>JAK2</i> (V617F) was detected on granulocyte DNA (38% mutant alleles). Bone marrow biopsy was consistent with a diagnosis of ET; in particular, there was no significant increase or left shift in neutrophil granulopoiesis or erythropoiesis.	The patient was given low-dose aspirin. Three years later, she developed erythrocytosis (Hb, 16.5 g/dL and Hct, 48.2%). The <i>JAK2</i> (V617F) mutant allele burden was increased (65%), whereas serum erythropoietin was low 3.3 (mU/mL). Polycythemic transformation of ET was diagnosed, and a phlebotomy program aimed to maintain Hct $<45\%$ was associated to low-dose aspirin.
Case 4	Asymptomatic, elderly patient with incidental thrombocytosis and the <i>JAK2</i> (V617F) mutation (high-risk <i>JAK2</i> -mutant ET)	A 67-y-old man was found to have isolated thrombocytosis on a routine CBC count (PLT count $610 \times 10^9/L$). He previously had transurethral resection of the prostate for benign prostatic hyperplasia, and was taking a statin for hypercholesterolemia.	<i>JAK2</i> (V617F) was detected on granulocyte DNA (39% mutant alleles). Bone marrow biopsy showed megakaryocyte proliferation with increased numbers of enlarged, mature megakaryocytes. Grading of fiber density showed normal findings.	The patient was given low-dose aspirin (100 mg per day). Because of age greater than 60 y, a cytoreductive treatment with hydroxyurea was also started (1 g per day). In few months, the PLT count decreased to $256 \times 10^9/L$, and the dose of hydroxyurea was reduced to 500 mg per day.
Case 5	Asymptomatic, elderly patient with thrombocytosis, mild anemia and the <i>MPL</i> (W515L) mutation (<i>MPL</i> -mutant MDS/MPN-RS-T mimicking ET)	A 64-y-old woman was referred to us because a routine CBC count showed: Hb, 10.3 g/dL; MCV, 96 fL; WBC count, $6.39 \times 10^9/L$; ANC, $4.30 \times 10^9/L$; and PLT count, $730 \times 10^9/L$.	Tests for <i>JAK2</i> (V617F) and <i>CALR</i> exon 9 mutations were negative, and the <i>MPL</i> (W515L) mutation was detected on granulocyte DNA. Bone marrow aspirate showed erythroid dysplasia with megaloblastoid features, 60% ring sideroblasts, and large atypical megakaryocytes; bone marrow biopsy was consistent with a MDS/MPN. Mutation analysis of <i>SF3B1</i> showed a wild-type sequence.	A diagnosis of MDS/MPN-RS-T was made. The patient was given low-dose aspirin.

ANC, absolute neutrophil count; Hb, hemoglobin; Hct, hematocrit.

Table 2. Our diagnostic workup of patients with thrombocytosis

Fields/investigations	Questions and/or assessments
Familial history	Relatives with thrombocytosis or other known hematologic disorders
Medical history	Diseases or conditions that can be associated with thrombocytosis (eg, malignancy, inflammatory bowel disease, iron deficiency, splenectomy, bleeding) Vascular complications (thrombosis or bleeding) Comorbidities like diabetes, hypertension, or dyslipidemia
Lifestyle	Smoking, physical activity, dietary habits
Medications	Regular and/or recent use of drugs
Symptoms	Headache, vertigo, dizziness, tinnitus, erythromelalgia, paresthesias, or systemic symptoms (weight loss, night sweats, fever)
Physical examination	Presence of splenomegaly and/or hepatomegaly
First-level tests*	CBC count and evaluation of peripheral blood smear Evaluation of body iron status (serum iron, TIBC, transferrin saturation, and serum ferritin)† CRP Screening for <i>BCR-ABL1</i> rearrangement Tests for <i>JAK2</i> (V617F), <i>CALR</i> exon 9 indels, and <i>MPL</i> exon 10 mutations, to be performed sequentially on granulocyte DNA‡
Second-level tests	Bone marrow evaluation through bone marrow aspirate and biopsy (H&E or Giemsa, Gomori and Perls staining) Further laboratory tests (eg, von Willebrand factor when PLT count is $\geq 1000 \times 10^9/L$ or when an acquired von Willebrand syndrome is anyhow suspected) and radiological/ultrasound examinations

H&E, hematoxylin and eosin; TIBC, total iron-binding capacity.

*First-level tests are performed at the same time, with the only exception being tests for *JAK2* (V617F), *CALR* exon 9 indels, and *MPL* exon 10 mutations, which are performed sequentially: (1) *JAK2* (V617F); (2) if negative, *CALR* exon 9; (3) if negative, *MPL* exon 10.

†We use a battery of tests for the evaluation of body iron status because this allows for distinguishing between the hypoferrinemia of iron deficiency and that of inflammation.

‡Granulocytes belong to the myeloproliferative clone, whereas lymphocytes do not; therefore, the use of granulocyte DNA allows better detection sensitivity and is of fundamental importance for quantitative assessment of the mutant allele burden.

we will first use clinical vignettes illustrating representative cases of ET (Table 1) and will later consider specific situations of interest.

How we diagnose ET

Thrombocytosis is defined as a platelet (PLT) count $\geq 450 \times 10^9/L$. The major types of thrombocytosis include reactive (or secondary) thrombocytosis, clonal myeloid neoplasms, and familial or hereditary thrombocytosis.²¹ As the most common cause is a reactive process, at the time of the first visit we always consider secondary thrombocytosis through a complete interview, physical examination, and first-level tests as reported in Table 2 and Figure 1.

Assessment of symptom burden in MPNs has shown that although ET has the lowest symptom severity, the prevalence of constitutional symptoms reported by patients is relatively high.²² It should be noted, however, that in this study patients were an average of 6.7 years out from diagnosis at survey completion. In our experience, most patients with ET are asymptomatic at diagnosis, and detection of thrombocytosis is typically incidental.

First-level laboratory tests include screening for mutations in the 3 MPN driver genes (Figure 1). In a recent study of 745 patients,¹⁰ we

found that 466 (62%) carried *JAK2* (V617F), 176 (24%) had *CALR* exon 9 indels, and 28 (4%) had *MPL* exon 10 mutations: only 75 (10%) patients did not carry any of the above driver mutations. In our practice, search for *JAK2* (V617F) on granulocyte DNA is the initial investigation performed in all patients with suspected ET; if *JAK2* (V617F) is absent, we screen for *CALR* exon 9 indels, and then, if this latter screening is also negative, we search for *MPL* exon 10 mutations.

Once the results of first-level tests are available, we follow the flowchart reported in Figure 1. The detection of a driver mutation confirms the presence of a myeloid neoplasm, but the absence does not rule out this possibility because as many as 1 in 10 ET patients can be triple negative, that is, negative for canonical mutations in the above driver genes. Two recent studies have indeed shown that a few triple-negative patients carry activating mutations of *MPL* outside exon 10, and that these noncanonical mutations may be either inherited or somatically acquired.^{23,24} One study has also shown that some patients carry noncanonical, activating mutations of *JAK2*, which appear to be germ line in most instances.²³ Finally, some patients have evidence of polyclonal hematopoiesis, and most likely do not have a true MPN.^{23,24} Thus, the so-called triple-negative cases may include patients with ET associated with noncanonical mutations of *MPL*, individuals with hereditary thrombocytosis (see “Distinguishing familial ET from hereditary thrombocytosis”), and also subjects with nonclonal thrombocytosis (Figure 1).

The myelodysplastic (MDS)/MPN with ring sideroblasts and thrombocytosis (MDS/MPN-RS-T) can mimic ET.²⁵ Most patients with MDS/MPN-RS-T have a combination of *SF3B1* mutation (as a driver genetic lesion) and *JAK2*, *MPL*, or *CALR* mutation (as a subclonal genetic lesion); however, up to one-third of patients may have wild-type *SF3B1*.²⁵⁻²⁷ Recent reports have described an atypical MPN associated with both *BCR-ABL1* rearrangement and *CALR* mutation²⁸⁻³⁰; this further underlines the importance of strictly adhering to the WHO criteria, screening for *BCR-ABL1* in the diagnostic approach.

An interesting study has shown that about one-fourth of ET patients carry additional somatic mutations in non-MPN driver genes.¹⁴ Although in the whole population of MPN patients the presence of 2 or more somatic mutations represented a negative prognostic factor, its significance in ET patients was less clear.

In our clinical practice, we are currently using the 2016 WHO criteria for the diagnosis of ET, as reported in Table 3.² Because these criteria have underlined the importance of distinguishing true ET from early prefibrotic stages of PMF, Table 3 also includes the 2016 WHO diagnostic criteria for prefibrotic myelofibrosis.

Clinical vignettes: establishing diagnosis

Clinical vignettes are explored in detail in Table 1.

Case 1: Low-risk *JAK2*-mutant ET

This woman had normal body iron status and no evidence of inflammation. *JAK2* (V617F) was detected on granulocyte DNA with a low percentage of mutant alleles, which is a common finding in ET,³¹ and a bone marrow biopsy unequivocally confirmed the diagnosis of ET.

Case 2: Low-risk *CALR*-mutant ET

This young woman had normal body iron status and a normal C-reactive protein (CRP). Because *JAK2* (V617F) was not detected on granulocyte DNA, *CALR* exon 9 was sequenced, and the type 1 *CALR* mutation (c.1092_1143del, L367fs*46) was detected. Bone marrow biopsy showed normal age-adjusted cellularity, and an increased

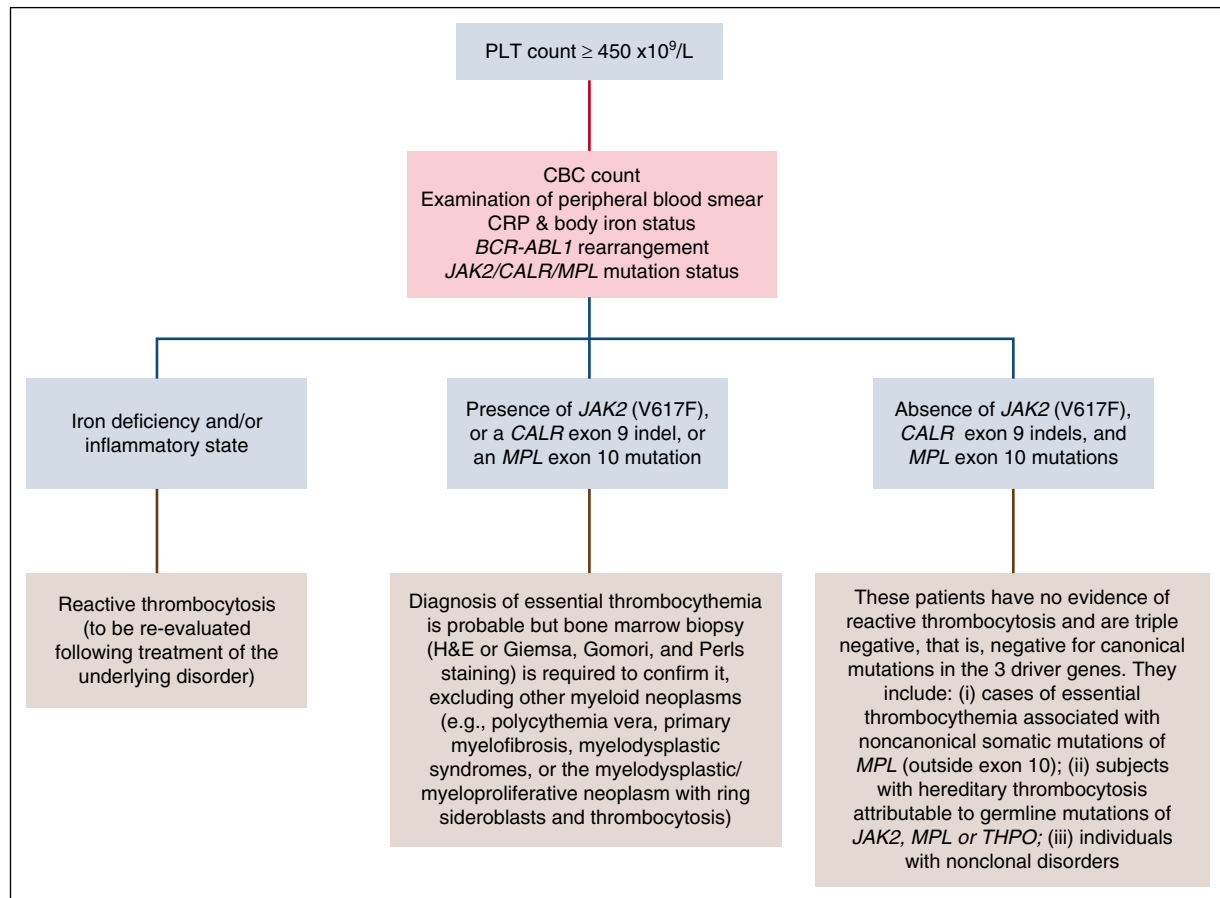

Figure 1. Our approach to the differential diagnosis of thrombocytosis. For the analysis of *JAK2/CALR/MPL* mutations status, we use granulocyte DNA and perform the following tests sequentially: (1) a quantitative polymerase chain reaction–based allelic discrimination assay for *JAK2* (V617F) with a sensitivity of <0.1%; (2) if *JAK2* (V617F) is absent, Sanger sequencing for detection of *CALR* exon 9 indels; (3) if *JAK2* (V617F) is absent and *CALR* exon 9 is wild type, a high-resolution melt assay for detection of *MPL* exon 10 mutations followed by Sanger sequencing in case of mutant pattern. H&E, hematoxylin and eosin.

number of giant megakaryocytes; reticulin fibrosis was absent. A final diagnosis of *CALR*-mutant ET was performed; *CALR* mutation is often associated with a very high platelet count,^{10,11} as in this case.

Case 3: *JAK2*-mutant ET progressing to PV

The initial diagnosis of ET was based on the complete blood cell (CBC) count, positivity for *JAK2* (V617F), and a typical bone marrow biopsy. Three years later, this woman developed erythrocytosis: serum erythropoietin was low at this time whereas the granulocyte *JAK2* (V617F)-mutant allele burden was increased, indicating a polycythemic transformation. We did not repeat bone marrow biopsy because a diagnosis of PV could be made otherwise according to the British Committee for Standards in Hematology (BCSH) criteria,³² and more importantly because a phlebotomy program was already indicated. *JAK2* (V617F)-mutant ET has a cumulative risk of polycythemic transformation equal to 29% at 15 years.¹⁰ We check the *JAK2* (V617F)-mutant allele burden during follow-up in all patients who show an increase in hemoglobin level above the upper normal limit.

Case 4: High-risk *JAK2*-mutant ET

The diagnostic process was simple in this man. He had normal body iron status and no evidence of inflammation, and more importantly he carried *JAK2* (V617F). This case is reported mainly to emphasize the concept that advanced age represents a risk factor for thrombosis per se.

Case 5: *MPL*-mutant MDS/MPN-RS-T mimicking ET

The combination of mild anemia and thrombocytosis suggested MDS/MPN-RS-T: this diagnosis was confirmed by the examination of bone marrow aspirate and biopsy, including Perls staining. No *SF3B1* mutation was detected in this woman, as happens in about one-third of these patients. This case illustrates the importance of performing bone marrow aspirate and biopsy to make an accurate morphologic diagnosis of ET and to distinguish this disorder from other myeloid neoplasms. To this purpose, evaluation of bone marrow biopsy should always include Perls and Gomori staining: without Perls staining, this patient might have been misdiagnosed as *MPL*-mutant ET.

How we communicate diagnosis of ET

We inform our patients that ET belongs to MPNs and that these are disorders of the bone marrow characterized by excessive production of peripheral blood cells. We underline that although ET is a tumor (that is, a neoplasm), this is a chronic disorder with a minimal impact on the patient's life expectancy.³³ We also explain that ET is an acquired disorder and that the driver mutation (in *JAK2*, *CALR*, or *MPL*) is always somatically acquired. Although familial cases exist,^{34,35} likely caused by a genetic predisposition to acquire the above somatic mutations, we emphasize that ET cannot be directly inherited by the

Table 3. 2016 WHO diagnostic criteria for ET compared with those for prefibrotic myelofibrosis

Diagnostic criteria	Major criteria	Minor criteria
For ET (Diagnosis of ET requires meeting all 4 major criteria or the first 3 major criteria and the minor criterion)	<ol style="list-style-type: none"> 1. PLT count $\geq 450 \times 10^9/L$ 2. Bone marrow biopsy showing proliferation mainly of the megakaryocyte lineage with increased numbers of enlarged, mature megakaryocytes with hyperlobulated nuclei. No significant increase or left shift in neutrophil granulopoiesis or erythropoiesis and very rarely minor (grade 1) increase in reticulin fibers 3. Not meeting WHO criteria for <i>BCR-ABL1</i>⁺ chronic myeloid leukemia, PV, PMF, MDSs, or other myeloid neoplasms 4. Presence of <i>JAK2</i>, <i>CALR</i>, or <i>MPL</i> mutation 	Presence of a clonal marker or absence of evidence for reactive thrombocytosis
For prefibrotic myelofibrosis (Diagnosis of prefibrotic myelofibrosis requires meeting all 3 major criteria, and at least 1 minor criterion)	<ol style="list-style-type: none"> 1. Megakaryocytic proliferation and atypia, without reticulin fibrosis $>$grade 1, accompanied by increased age-adjusted bone marrow cellularity, granulocytic proliferation, and often decreased erythropoiesis 2. Not meeting WHO criteria for <i>BCR-ABL1</i>⁺ chronic myeloid leukemia, PV, ET, MDSs, or other myeloid neoplasms 3. Presence of <i>JAK2</i>, <i>CALR</i>, or <i>MPL</i> mutation or in the absence of these mutations, presence of another clonal marker, or absence of minor reactive bone marrow reticulin fibrosis 	Presence of at least 1 of the following, confirmed in 2 consecutive determinations: <ol style="list-style-type: none"> a. Anemia not attributed to a comorbid condition b. Leukocytosis (WBC count $\geq 11 \times 10^9/L$) c. Palpable splenomegaly d. Lactate dehydrogenase level increased to above upper normal limit of institutional reference range

Information is from Arber et al.²

progeny. We suggest screening of relatives only in familial trees with 2 or more subjects affected with MPNs (see “Distinguishing familial ET from hereditary thrombocytosis”).

We then illustrate the 3 most important complications that can occur during follow-up^{10,36}: (1) vascular complication (15-year cumulative risk of thrombosis ranging from 10% to 25% depending on the molecular subtype, higher in *JAK2*-mutant than in *CALR*-mutant ET)¹⁰; (2) progression to myelofibrosis (15-year cumulative risk of about 10% on average, higher in type 1 *CALR*-mutant than in *JAK2*-mutant ET)³⁷; and (3) leukemic transformation (15-year cumulative risk of about 3% on average).¹⁰

Very often, patients ask whether they should modify their dietary habits, physical activity, or their lifestyle in general. We recommend continuing a normal life without deprivation of food, sports, and enjoyment, just taking into account that antiplatelet therapy may expose the patient to bleeding in the case of extreme sports. We advise stopping

smoking and recommend treating obesity, hypertension, and dyslipidemia. Finally, we discuss the importance of an optimal follow-up. We suggest checking CBC count regularly, monthly if a cytoreductive treatment is started, and planning a hematologic visit every 6 months. When the condition is stable, CBC counts can be checked less frequently. Abdominal ultrasound is recommended when myelofibrotic transformation is suspected based on clinical and/or hematologic criteria.

How we treat patients with ET according to their individual risk

Currently available treatments for ET patients are mainly aimed at minimizing the risk of thrombosis and/or bleeding. As shown in Table 4, age ≥ 60 years, history of vascular complications (thrombosis

Table 4. Risk adapted treatment of patients with ET

Risk category	Our therapeutic approach
Low risk (age < 60 y AND no history of thrombosis or major bleeding AND PLT count $< 1500 \times 10^9/L$, ie, none of the 3 major risk factors)	<i>JAK2</i> (V617F)-mutant ET <ul style="list-style-type: none"> • Low-dose aspirin* <i>CALR</i> -mutant ET, <i>MPL</i> -mutant ET and triple-negative patients <ul style="list-style-type: none"> • Low-dose aspirin* in patients with at least 1 concomitant cardiovascular risk factor† and/or with microvascular symptoms • Observation alone or low-dose aspirin* in patients without concomitant cardiovascular risk factors‡ and without microvascular symptoms (individual decision-making)‡
High risk (age ≥ 60 y AND/OR history of thrombosis or major bleeding AND/OR PLT count $\geq 1500 \times 10^9/L$, ie, at least 1 of the 3 major risk factors)	<ul style="list-style-type: none"> • Low-dose aspirin* + cytoreductive therapy

Risk stratification is based on the European LeukemiaNet recommendations: age ≥ 60 y, history of thrombosis or major bleeding, and PLT count $\geq 1500 \times 10^9/L$ are the 3 risk factors used for this stratification.

*If PLT count is $\geq 1000 \times 10^9/L$ and/or clinical manifestations include bleeding, the possibility of an acquired von Willebrand syndrome (AVWS) should be considered: von Willebrand factor antigen level and ristocetin cofactor activity should therefore be assessed. If AVWS is diagnosed, the use of low-dose aspirin is contraindicated; in any case, we do not use aspirin in high-risk patients whose PLT count is $\geq 1500 \times 10^9/L$.

†Cardiovascular risk factors include hypertension, diabetes, dyslipidemia, and active tobacco use.

‡We provide the patient with the information he/she needs to understand the benefit-risk balance of taking low-dose aspirin for years, considering age, occupation, and lifestyle, and then support his/her choice.

Table 5. How we use cytoreductive drugs in patients with ET who need a cytoreductive treatment according to the risk stratification reported in Table 4

Patient's age*	First-line treatment†	Second-line treatment
<40 y: Only 15% of patients under the age of 40 y need a cytoreductive treatment, either because of previous thrombosis or a PLT count $\geq 1500 \times 10^9/L$	Interferon α : Interferon α targets the mutant clone and therefore is a potential disease-modifying drug; in addition, it has no gonadal toxicity and no teratogenic or mutagenic effect	Hydroxyurea (or anagrelide‡)
40-60 y: Only 20% of patients between the age of 40 and 60 y need a cytoreductive treatment, either because of previous thrombosis or a PLT count $\geq 1500 \times 10^9/L$	Interferon α or hydroxyurea: The choice depends on the patient's occupation, lifestyle, desires, and expectations	Hydroxyurea or interferon α (or anagrelide‡)
>60 y: All patients need a cytoreductive treatment because of age	Hydroxyurea: Hydroxyurea involves fewer side-effects than interferon α and findings of observational studies suggest that this drug does not increase the risk of leukemic transformation. In our experience, significant side effects are found in <5% of patients and resistance to treatment is relatively uncommon	Busulfan (or interferon α §)

We use regular interferon α for treatment of ET following the indications and reimbursement criteria of the Italian Medicines Agency (AIFA); it should be noted, however, that pegylated forms of interferon α with better tolerance are used in many countries worldwide. Considering age distribution and proportions of patients who need a cytoreductive treatment at different age intervals (left column), with our approach the vast majority of patients are given hydroxyurea, and <1 in 10 are given interferon α .

*Proportion of patients needing treatment based on the experience of the Department of Hematology Oncology, Fondazione IRCCS Policlinico San Matteo, Pavia, Italy.

†Rationale for the use of the specific cytoreductive drug.

‡We consider anagrelide as a second-line treatment in patients who refuse our proposal (hydroxyurea or interferon α).

§We consider interferon α as a second-line treatment in patients over the age of 60 y who refuse treatment with busulfan.

or major bleeding), and PLT count $\geq 1500 \times 10^9/L$ are the 3 risk factors used to classify patients with ET into low (no risk factors) and high risk (1 or more risk factors).³⁸ A PLT count $\geq 1500 \times 10^9/L$ represents an indication to cytoreductive treatment because extreme thrombocytosis is frequently associated with acquired von Willebrand syndrome.³⁸ The International Prognostic Score for Essential Thrombocythemia (IPSET) is based on age >60 years, white blood cell (WBC) count $>11 \times 10^9/L$, and history of thrombosis³; although it provides prognostic information, we do not use it for clinical decision-making at present.

As illustrated in Table 4, in our current practice we treat low-risk patients with low-dose aspirin or just follow them regularly; we treat high-risk patients with low-dose aspirin combined with a cytoreductive treatment.

According to the European LeukemiaNet (ELN) recommendations,³⁸ all ET patients should be managed with low-dose aspirin if microvascular disturbances are present. A study conducted on low-risk ET patients showed that antiplatelet therapy reduces the incidence of venous thrombosis in *JAK2*-mutated patients and the rate of arterial thrombosis in those with cardiovascular risk factors.³⁹ In the remaining low-risk patients, antiplatelet therapy was not effective as primary prophylaxis of thrombosis. Subsequent studies have confirmed that cardiovascular risk factors and *JAK2* (V617F) represent independent risk factors for thrombosis in ET.^{4,40,41} A more recent work has evaluated the benefit-to-risk ratio of low-dose aspirin in 433 low-risk ET patients who were on antiplatelet therapy or observation only.⁴² In *JAK2* (V617F)-mutated patients, low-dose aspirin was associated with a reduced incidence of venous thrombosis with no effect on the risk of bleeding. By contrast, in *CALR*-mutated patients, antiplatelet therapy did not affect the risk of thrombosis whereas it was associated with a higher incidence of bleeding. Thus, the available evidence indicates that *JAK2* (V617F) plays a major role in the pathogenesis of thrombosis, whereas *CALR* or *MPL* mutation and triple negativity identify patients with lower thromboembolic risk.

Based on the available evidence, we use low-dose aspirin in ET patients as summarized in Table 4. We prescribe aspirin 100 mg once daily, preferably at the end of a meal, and do not try to modulate the dosing interval as suggested by a study on thromboxane biosynthesis.⁴³ We administer antiplatelet therapy to all high-risk ET patients with the

only exception being those with extreme thrombocytosis ($\geq 1500 \times 10^9/L$). In low-risk patients, we base our decision on the molecular subtype and the presence of cardiovascular risk factors or microvascular symptoms (Table 4). In case of marked thrombocytosis ($\geq 1000 \times 10^9/L$) or of any evidence of bleeding, before starting low-dose aspirin, we assess von Willebrand factor in terms of antigen level and ristocetin cofactor activity to exclude an acquired von Willebrand syndrome; if present, we do not administer aspirin. In case of gastric intolerance, we suggest taking antacid drugs or switching to ticlopidine.

Although cytoreductive treatment is not indicated in low-risk ET patients who have an incidence of thrombosis similar to that of a healthy control population,⁴⁴ it is definitely indicated in high-risk patients.^{45,46} Our criteria for the choice of the optimal cytoreductive drug are reported in Table 5.

The ELN experts recommended hydroxyurea as first-line cytoreductive therapy at any age, although they also underlined that its use should be carefully considered in patients younger than 40 years of age.³⁸ In our current practice, we start hydroxyurea at a dose of 1 g per day, and then modify the dose according to the hematologic response. The objective of treatment is dual, that is: (1) to lower PLT count below $450 \times 10^9/L$ and (2) to correct leukocytosis (WBC count $\geq 11 \times 10^9/L$), if present. We consider correcting leukocytosis very important, whereas we are relatively flexible with respect to the PLT count: actually, we consider acceptable also values between $450 \times 10^9/L$ and $600 \times 10^9/L$, especially if these values can be achieved with lower doses of hydroxyurea (eg, 500 mg per day). Our clinical practice is supported by a number of studies showing that the actuarial probability of thrombosis is influenced by leukocytosis and not by PLT count.⁴⁷⁻⁵⁰ In the prospective Thrombocythemia 1 Trial (PT-1) cohort, PLT count outside of the normal range during follow-up was not associated with a risk of thrombosis, but rather with a risk of bleeding.⁵⁰

In patients younger than 40 years of age and in selected cases between 40 and 60 years of age (Table 5), we use interferon α : this represents an off-label use because ET is not an approved indication. Although there is no evidence that hydroxyurea can increase the risk of leukemic transformation,⁵¹ this drug is not completely devoid of

Table 6. Clinical vignettes illustrating specific situations that can be encountered in patients with ET

Case	Situation
Case 6: Familial ET	A 26-y-old woman (proband in Figure 2) was diagnosed with <i>JAK2</i> (V617F)-mutant ET after the incidental discovery of thrombocytosis. During the diagnostic workup (described in Table 2), we learned that 1 uncle was followed in another hospital because of ET. Considering the familial history, we decided to perform a CBC count and to screen for <i>JAK2</i> (V617F) in all family members. The patient's father had thrombocytosis and carried <i>JAK2</i> (V617F): a bone marrow biopsy confirmed a diagnosis of ET (Figure 2). The remaining relatives had normal CBC counts and no evidence of <i>JAK2</i> (V617F).
Case 7: A woman with ET becomes pregnant	A 35-y-old woman followed at our Department for a low-risk <i>JAK2</i> (V617F)-mutant ET (PLT count at diagnosis equal to $726 \times 10^9/L$, no history of thrombosis or major bleeding) became pregnant. Three years before, she had had a pregnancy complicated by severe preeclampsia that required preterm delivery at the 30th week. Before conception, she was treated with low-dose aspirin: when she became pregnant, we added LMWH to low-dose aspirin throughout pregnancy. This woman had a normal delivery.
Case 8: ET complicated by SVT	A 40-y-old woman was diagnosed with low-risk <i>JAK2</i> (V617F)-mutant ET in 2005 (PLT count at diagnosis equal to $706 \times 10^9/L$, no history of thrombosis) and was given low-dose aspirin. She had a history of recurrent miscarriages (4 previous events before diagnosis of ET). Two years later, she was admitted to our hospital because of abdominal pain; abdomen ultrasound and computed tomography scan showed massive splenic-portal thrombosis. Positivity for lupus anticoagulant was found, and anticoagulation with LMWH was started, followed by warfarin. Because this was now a high-risk condition, we started a cytoreductive treatment with hydroxyurea. After 6 y of hydroxyurea, we enrolled this patient into a clinical trial on the use of the JAK inhibitor ruxolitinib for treatment of SVT associated with MPNs. Under ruxolitinib treatment, she obtained complete normalization of the CBC and complete regression of splenomegaly; reduction of spleen volume was confirmed with sequential magnetic resonance imaging.
Case 9: ET resistant to conventional treatments and responsive to ruxolitinib	A 25-y-old man was referred to our Department in 2005 because of extreme thrombocytosis (PLT counts steadily $>1500 \times 10^9/L$). At that time, we made a diagnosis of <i>JAK2</i> (V617F)-negative ET and, because of the extreme thrombocytosis and the young age, we started a treatment with interferon α . Twelve months later, interferon treatment was discontinued because of lack of hematologic response, and hydroxyurea was started. Despite a dose of 2 g per day, this treatment was also ineffective and PLT count increased to $>2000 \times 10^9/L$. This patient was therefore enrolled into a clinical trial on the use of ruxolitinib ⁸⁴ : his PLT count decreased to about $600 \times 10^9/L$, and remained stable around this value. This patient was recently found to carry a <i>CALR</i> mutation.

adverse effects⁵²; more importantly, it does not specifically target the mutant clone and is therefore unlikely to modify the natural history of disease. On the contrary, pegylated interferon α -2a has been shown to induce sustained complete molecular response in a subset of patients with *JAK2* (V617F)-mutant ET.^{53,54} In addition, recent reports describe the positive effect of interferon α in patients with *CALR*-mutant ET^{16,55}; this treatment was found to produce high rates of hematologic and molecular responses that in some cases could be maintained after discontinuation of the drug.⁵⁵ Although these observations do not necessarily mean that interferon α can modify the natural history of disease, they at least indicate that this drug can target the myeloproliferative clone.⁵⁶

Before starting treatment with interferon α , we suggest evaluating liver and thyroid function, and excluding the presence of autoantibodies (anti-nuclear and anti-double-stranded DNA antibodies, rheumatoid factor, and anti-neutrophil cytoplasmic antibodies). We generally start with 3×10^6 /million units of interferon α 3 times a week, and then titrate the dose according to efficacy and side-effects. To avoid flu-like symptoms, we recommend the use of paracetamol, 1000 mg per os, at the beginning of treatment. Adverse effects of interferon α treatment are not trivial, and include, besides flu-like symptoms, nausea, fatigue, and psychiatric sequelae.⁵⁷ Previous studies have indeed reported discontinuation of treatment in almost one-fourth of cases.⁵⁸ Patients must therefore be supported and motivated, underlying that this represents so far the only treatment capable of targeting the mutant cells in their bone marrow.

The PT-1 trial showed that hydroxyurea plus low-dose aspirin is superior to anagrelide plus low-dose aspirin for patients with ET at high

risk for vascular events.⁵⁹ More recently, the ANAHYDRET study concluded that anagrelide is not inferior compared with hydroxyurea in the prevention of thrombotic complications in patients with ET diagnosed according to the 2008 WHO criteria.⁷ The US Food and Drug Administration (FDA) has approved anagrelide for the treatment of ET, whereas the European Medicine Agency (EMA) has been more restrictive, approving the drug for treatment of patients with high-risk ET who are intolerant to their current therapy or whose elevated PLT counts are not reduced to an acceptable level by their current therapy. An expert panel has provided a definition of clinical resistance/intolerance to hydroxyurea in ET.⁶⁰ So far, we have only occasionally considered the use of anagrelide, mainly because the number of ET patients with resistance/intolerance to hydroxyurea is small in our experience. However, we are fully aware that anagrelide is widely used alone and in combination in other institutions.⁶¹ Because of the potential cardiovascular toxicity associated with anagrelide, especially in older patients, a careful cardiac evaluation is recommended before starting treatment.

Busulfan and pipobroman have been used as second-line treatment in older patients who are unresponsive or intolerant to hydroxyurea. We currently use busulfan to this purpose: before prescribing this drug, we inform the patient that alkylating agents and the sequential use of different cytoreductive treatments might increase the risk of leukemic transformation.^{36,51,62} Microvascular symptoms such as erythromelalgia and acroparesthesia generally resolve with low-dose aspirin. We consider an ad hoc cytoreductive treatment only in the few patients whose symptoms severely affect quality of life and do not respond to low-dose aspirin.

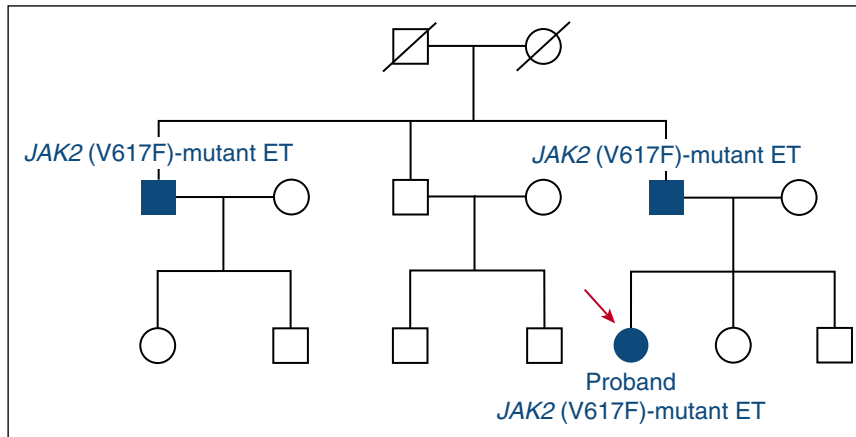

Figure 2. Familial ET. In this family, *JAK2* (V617F) was a somatically acquired mutation found in circulating granulocytes (with variable values for mutant allele burden in the different patients) but not in circulating T lymphocytes. Familial ET must be distinguished from hereditary thrombocytosis, a Mendelian genetic disease attributable to germ line mutations of *JAK2*, *MPL*, or *THPO*.

Clinical vignettes: defining the individual risk and deciding therapy

Clinical vignettes are explored in detail in Table 1.

Case 1: Low-dose aspirin in low-risk *JAK2*-mutant ET

This patient had low-risk *JAK2* (V617F)-mutant ET. She was given low-dose aspirin (100 mg per day) because *JAK2* (V617F) specifically involves a high risk of thrombosis.¹⁰ This patient is currently seen a couple of times a year in the Outpatient Department.

Case 2: Low-risk *CALR*-mutant ET with acquired von Willebrand syndrome

This woman had *CALR*-mutant ET and a history of oral mucosal bleeding after tooth brushing. Because of marked thrombocytosis (PLT count, $1069 \times 10^9/L$), we assessed von Willebrand factor and found reduced ristocetin cofactor activity (30%) associated with normal antigen level, a combination that indicates an acquired von Willebrand syndrome. We decided on a watchful-waiting strategy: cytoreductive treatment with interferon α would be considered if PLT count increases to $\geq 1500 \times 10^9/L$ and/or bleeding becomes more severe.

Case 3: *JAK2*-mutant ET requiring phlebotomies because of progression to PV

This woman had low-risk *JAK2* (V617F)-mutant ET and therefore we prescribed low-dose aspirin. She then progressed to PV and a phlebotomy program to maintain hematocrit $<45\%$ was started. Her subsequent clinical course has been characterized by a progressive increase in PLT count due to the iron deficiency caused by phlebotomies. If PLT count increases to $\geq 1500 \times 10^9$ and/or leukocytosis develops, we would discontinue phlebotomies and start a cytoreductive treatment with hydroxyurea.

Case 4: Low-dose aspirin and hydroxyurea in high-risk *JAK2*-mutant ET

This man was over 60 years of age and therefore had high-risk *JAK2* (V617F)-mutant ET. He was treated with low-dose aspirin and hydroxyurea (1 g per day); PLT count normalized quickly and remained steadily below $300 \times 10^9/L$ after the dose of hydroxyurea was reduced to 500 mg per day. This optimal response to hydroxyurea is not uncommon in patients with *JAK2* (V617F)-mutant ET.

Case 5: Lack of evidence regarding treatment of a rare myeloid neoplasm

MDS/MPN-RS-T is a very rare disease and the available evidence regarding its treatment is limited. We do not use cytoreductive drugs in these patients because they might significantly worsen anemia and/or negatively impact on the risk of leukemic transformation. Low-dose aspirin was given to this 64-year-old woman for primary prevention of thromboembolic complications.

Distinguishing familial ET from hereditary thrombocytosis

Case 6 in Table 6 illustrates our approach to the identification of familial cases of ET.

Familial thrombocytosis includes hereditary thrombocytosis and familial ET. Hereditary thrombocytosis may be associated with germ line mutations of *THPO*, the thrombopoietin gene,^{63,64} or *MPL*, the thrombopoietin receptor gene.^{23,24,65} Recent reports have described cases of hereditary thrombocytosis associated with noncanonical germ line mutations of *JAK2*.^{23,66-69} In familial ET, *JAK2* (V617F) is always a somatically acquired event, as in the familial tree reported in Figure 2.^{34,70,71}

In our clinical practice, we interview all patients with thrombocytosis to find out if there is a family history of thrombocytosis or MPN. In familial trees with at least 2 cases of MPN, we suggest performing a CBC count in all apparently healthy relatives with the aim of identifying an early asymptomatic MPN phenotype. We manage and treat patients with familial ET in the same way as patients with sporadic ET; a recent study found survival to be similar in familial and sporadic MPN patients.⁷²

In familial trees with suspected hereditary thrombocytosis, we now sequence the entire coding region of *JAK2* and *MPL* as well as the *THPO* gene.

How we manage pregnancy in *JAK2* with ET

Case 7 in Table 6 provides an example of how we manage pregnancy in a woman with ET.

ET occurs in women of childbearing age and pregnancy is a relatively common issue in the clinical management of young women

Table 7. Areas of uncertainty and perspectives regarding the treatment of patients with ET

	Perspectives
Areas of uncertainty in the management of ET	<ul style="list-style-type: none"> • Triple-negative patients. These cases may include patients with ET associated with noncanonical mutations of <i>MPL</i>, subjects with hereditary thrombocytosis attributable to germ line mutations of <i>JAK2</i>, <i>MPL</i>, or <i>THPO</i>, and individuals with nonclonal disorders. Although these patients generally have a favorable outcome, the above conditions differ substantially: clinical decision-making is therefore challenging. • Relevance of leukocytosis for clinical decision-making. ET patients may have 1 or more features of prefibrotic myelofibrosis (see minor criteria in Table 3: anemia, leukocytosis, palpable splenomegaly, and increased lactate dehydrogenase level) without fulfilling the 2016 WHO diagnostic criteria for this latter condition. These features may suggest a more advanced disease, presumably a transition to myelofibrosis. Leukocytosis has been found to be an independent predictor of poor clinical outcome, in terms of both thrombosis risk and reduced survival.^{3,47,49,50} It is currently unclear how this information should be used in clinical decision-making. • Low-dose aspirin in low-risk patients with <i>CALR</i>-mutant ET. A recent retrospective study has shown that in patients with low-risk <i>CALR</i>-mutant ET, low-dose aspirin does not reduce the risk of thrombosis and may increase the risk of bleeding.⁴² This observation suggests a genotype-based approach to antiplatelet therapy in low-risk patients, and observation alone appears a reasonable option for those with <i>CALR</i>-mutant ET without concomitant cardiovascular risk factors and without microvascular symptoms. • Optimal treatment of low-risk patients with <i>JAK2</i>-mutant ET and concomitant cardiovascular risk factors. According to current recommendations, these patients are treated with low-dose aspirin. However, more aggressive treatments have been suggested, including twice-daily aspirin⁴¹ and the use of a cytoreductive drug.⁴²
Potential disease-modifying drugs for treatment of ET	<ul style="list-style-type: none"> • Pegylated interferon α-2a is currently evaluated in the clinical trial entitled "Randomized trial of pegylated interferon alfa-2a vs hydroxyurea in PV and ET" (ClinicalTrials.gov Identifier: NCT01259856). • Ropeginterferon α-2 has been shown to induce hematologic and molecular responses with low toxicity in patients with PV.⁸⁸ • Ruxolitinib was found to be effective in patients with ET who were refractory or intolerant to hydroxyurea, inducing complete molecular responses in some cases.^{84,85}

with this disorder. Previous studies have shown live birth rates of 50% to 70%, and spontaneous abortion rates of 25% to 50%, mostly during the first trimester.⁷³ The pathogenesis of these complications is unclear; age, parity, thrombophilia, PLT count, WBC count, and hemoglobin level have not been found to be predictive of pregnancy outcome in ET.⁷⁴⁻⁷⁶ Whether the use of aspirin can improve pregnancy outcome is uncertain⁷⁴⁻⁷⁷; however, a meta-analysis of randomized trials conducted outside ET concluded that low-dose aspirin is effective in preventing preeclampsia, being safe for both mother and fetus.⁷⁸ Pregnancy complications in women with ET are associated with a higher risk of subsequent thrombosis.⁷⁹

In our practice, we inform the patient and her partner that pregnancy is not discouraged in ET, although they should be aware that the risk of fetal loss is 3 times higher compared with that of healthy women. We recommend aspirin for all pregnant women with ET, unless contraindicated. If PLT count is $\geq 1000 \times 10^9/L$, an acquired von Willebrand syndrome should be excluded as indicated before. In agreement with the ELN recommendations, we add low-molecular-weight heparin (LMWH) to low-dose aspirin in case of previous major thrombosis or severe pregnancy complication, and consider interferon α if the PLT count is $\geq 1500 \times 10^9/L$ or in case of previous major bleeding.³⁸

We discuss with obstetricians and anesthesiologists the optimal time to discontinue antiplatelet treatment (generally about 2 weeks before delivery) in order to account for any possible event, including instrumental delivery and epidural or spinal anesthesia. After delivery, we recommend treating all women with ET with LMWH for 6 weeks to prevent deep vein thrombosis.⁷⁹

Returning to case 7, we used a combination of low-dose aspirin and LMWH as this pregnancy was classified as high risk because of the previous history of severe preeclampsia with preterm delivery.

Potentially catastrophic events: how we manage SVT in patients with ET

Case 8 in Table 6 provides an example of how we manage splanchnic vein thrombosis (SVT) in patients with ET.

MPNs are the leading cause of SVT, being responsible for about half of cases of Budd-Chiari syndrome and one-third of cases of portal vein thrombosis.⁸⁰ In a meta-analysis of 831 patients with SVT, the mean prevalence of positivity for *JAK2* (V617F) was 32.7%⁸¹; because this may be the first marker of a latent MPN, we recommend routine screening for *JAK2* (V617F) in patients with a SVT. Although the incidence of *CALR* mutations is low in patients with SVT,⁸² we have now also included mutation analysis of *CALR* exon 9 in the workup of these subjects.

Genetic and acquired thrombophilia, in particular the presence of an antiphospholipid syndrome, should be studied in all cases of ET with SVT. Because ET patients with genetic or acquired thrombophilia are at high risk of recurrent thrombosis,⁸³ we prescribe cytoreductive treatment (generally hydroxyurea) and oral anticoagulation through life. These patients should be regularly monitored for portal hypertension and esophageal varices.

Resistance to conventional treatments and the use of experimental drugs

Case 9 in Table 6 provides an example of the efficacy of ruxolitinib in a patient with ET who was resistant to conventional treatments, including interferon α and hydroxyurea.

In a phase 2 open-label study,⁸⁴ ruxolitinib treatment was well tolerated in a population of patients with ET who were refractory or intolerant to hydroxyurea, and resulted in improvements in PLT count

and disease-related symptoms in most cases. Interestingly, 2 patients with *JAK2* (V617F)-mutant ET enrolled in this study achieved complete molecular remission after 5 years of ruxolitinib treatment.⁸⁵ It should also be noted that patient 8 (Table 6) had a complete hematologic response to ruxolitinib after enrollment in a clinical trial on the use of this JAK inhibitor for treatment of SVT associated with MPNs.

In a phase 2, open-label study, the telomerase inhibitor imetelstat has been administered to 18 patients with ET who had not had a response to or who had unacceptable side-effects from prior therapies.⁸⁶ This study showed hematologic and molecular responses but also nonnegligible adverse events. It has been suggested that imetelstat may change the natural history of MPN,⁸⁷ but its side-effect profile appears hardly acceptable in ET patients.

Conclusions and perspectives

Although our understanding of the genetic basis of ET has improved considerably in the last few years, there has been less progress than we would have liked in the management of this disorder. Low-dose aspirin combined with hydroxyurea may represent a satisfactory treatment of patients over the age of 60 years, but there is a need of disease-modifying drugs for younger patients. Current areas of uncertainty in the management of ET patients are reported in Table 7.

Table 7 also includes a list of potential disease-modifying drugs. The ongoing randomized trial of pegylated interferon α -2a vs hydroxyurea in PV and ET (ClinicalTrials.gov Identifier: NCT01259856) may provide important information about the ability of this drug to modify the natural history of disease. Ropoginterferon α -2, a mono-pegylated interferon α -2b isoform that can be administered every 2 weeks, has been recently shown to be safe and effective in the treatment of PV⁸⁸; in this study, two-thirds of patients showed a

reduction in the *JAK2*-mutant allele burden during treatment. Whether JAK inhibitors can provide beneficial effects in patients with ET remains to be established in ad hoc clinical trials, but ruxolitinib has already proved to be effective in patients with a relatively aggressive disease.⁸⁴

Acknowledgments

The authors thank their patients with MPNs for participating in their studies. Most of their studies on MPNs are currently done within the Associazione Italiana per la Ricerca sul Cancro (AIRC)–Gruppo Italiano Malattie Mieloproliferative project. The current investigations are funded by the following grants from AIRC, Milan, Italy: MFAG 2014 Id.15672; and Special Program Molecular Clinical Oncology 5×1000, #1005.

Authorship

Contribution: E.R. and M.C. conceived and wrote the manuscript. Conflict-of-interest disclosure: The authors declare no competing financial interests. ORCID profiles: E.R., 0000-0002-7572-9504; M.C., 0000-0001-6984-8817. Correspondence: Elisa Rumi, Department of Hematology Oncology, Fondazione IRCCS Policlinico San Matteo, Viale Golgi 19, 27100 Pavia, Italy; e-mail: elisa.rumi@unipv.it; or Mario Cazzola, Department of Hematology Oncology, Fondazione IRCCS Policlinico San Matteo, Viale Golgi 19, 27100 Pavia, Italy; e-mail: mario.cazzola@unipv.it.

References

1. Swerdlow SH, Campo E, Harris NL, et al. WHO Classification of Tumours of Haematopoietic and Lymphoid Tissues. Lyon, France: IARC; 2008.
2. Arber DA, Orazi A, Hasserjian R, et al. The 2016 revision to the World Health Organization classification of myeloid neoplasms and acute leukemia. *Blood*. 2016;127(20):2391-2405.
3. Passamonti F, Thiele J, Girodon F, et al. A prognostic model to predict survival in 867 World Health Organization-defined essential thrombocythemia at diagnosis: a study by the International Working Group on Myelofibrosis Research and Treatment. *Blood*. 2012;120(6):1197-1201.
4. Barbui T, Finazzi G, Carobbio A, et al. Development and validation of an International Prognostic Score of thrombosis in World Health Organization-essential thrombocythemia (IPSET-thrombosis). *Blood*. 2012;120(26):5128-5133, quiz 5252.
5. Godfrey AL, Chen E, Pagano F, et al. *JAK2*V617F homozygosity arises commonly and recurrently in PV and ET, but PV is characterized by expansion of a dominant homozygous subclone. *Blood*. 2012;120(13):2704-2707.
6. Rumi E, Pietra D, Guglielmelli P, et al; Associazione Italiana per la Ricerca sul Cancro Gruppo Italiano Malattie Mieloproliferative. Acquired copy-neutral loss of heterozygosity of chromosome 1p as a molecular event associated with marrow fibrosis in MPL-mutated myeloproliferative neoplasms. *Blood*. 2013;121(21):4388-4395.
7. Gisslinger H, Gotic M, Holowiecki J, et al; ANAHYDRET Study Group. Anagrelide compared with hydroxyurea in WHO-classified essential thrombocythemia: the ANAHYDRET Study, a randomized controlled trial. *Blood*. 2013;121(10):1720-1728.
8. Klampfl T, Gisslinger H, Harutyunyan AS, et al. Somatic mutations of calreticulin in myeloproliferative neoplasms. *N Engl J Med*. 2013;369(25):2379-2390.
9. Nangalia J, Massie CE, Baxter EJ, et al. Somatic CALR mutations in myeloproliferative neoplasms with nonmutated *JAK2*. *N Engl J Med*. 2013;369(25):2391-2405.
10. Rumi E, Pietra D, Ferretti V, et al; Associazione Italiana per la Ricerca sul Cancro Gruppo Italiano Malattie Mieloproliferative Investigators. *JAK2* or *CALR* mutation status defines subtypes of essential thrombocythemia with substantially different clinical course and outcomes. *Blood*. 2014;123(10):1544-1551.
11. Rotunno G, Mannarelli C, Guglielmelli P, et al; Associazione Italiana per la Ricerca sul Cancro Gruppo Italiano Malattie Mieloproliferative Investigators. Impact of calreticulin mutations on clinical and hematological phenotype and outcome in essential thrombocythemia. *Blood*. 2014;123(10):1552-1555.
12. Rampal R, Al-Shahrour F, Abdel-Wahab O, et al. Integrated genomic analysis illustrates the central role of *JAK-STAT* pathway activation in myeloproliferative neoplasm pathogenesis. *Blood*. 2014;123(22):e123-e133.
13. Allen C, Lambert JR, Linch DC, Gale RE. X chromosome inactivation analysis reveals a difference in the biology of ET patients with *JAK2* and *CALR* mutations. *Blood*. 2014;124(13):2091-2093.
14. Lundberg P, Karow A, Nienhold R, et al. Clonal evolution and clinical correlates of somatic mutations in myeloproliferative neoplasms. *Blood*. 2014;123(14):2220-2228.
15. Tefferi A, Guglielmelli P, Larson DR, et al. Long-term survival and blast transformation in molecularly annotated essential thrombocythemia, polycythemia vera, and myelofibrosis. *Blood*. 2014;124(16):2507-2513, quiz 2615.
16. Verger E, Cassinat B, Chauveau A, et al. Clinical and molecular response to interferon- α therapy in essential thrombocythemia patients with *CALR* mutations. *Blood*. 2015;126(24):2585-2591.
17. Marty C, Pecquet C, Nivarthi H, et al. Calreticulin mutants in mice induce an MPL-dependent thrombocytosis with frequent progression to myelofibrosis. *Blood*. 2016;127(10):1317-1324.
18. Chachoua I, Pecquet C, El-Khoury M, et al. Thrombopoietin receptor activation by myeloproliferative neoplasm associated calreticulin mutants. *Blood*. 2016;127(10):1325-1335.
19. Araki M, Yang Y, Masubuchi N, et al. Activation of the thrombopoietin receptor by mutant calreticulin in *CALR*-mutant myeloproliferative neoplasms. *Blood*. 2016;127(10):1307-1316.

20. Cazzola M. Mutant calreticulin: when a chaperone becomes intrusive. *Blood*. 2016;127(10):1219-1221.
21. Schafer AL. Thrombocytosis. *N Engl J Med*. 2004;350(12):1211-1219.
22. Emanuel RM, Dueck AC, Geyer HL, et al. Myeloproliferative neoplasm (MPN) symptom assessment form total symptom score: prospective international assessment of an abbreviated symptom burden scoring system among patients with MPNs [published correction appears in *J Clin Oncol*. 2012;30(36):4590]. *J Clin Oncol*. 2012;30(33):4098-4103.
23. Milosevic Feenstra JD, Nivarthi H, Gisslinger H, et al. Whole-exome sequencing identifies novel MPL and JAK2 mutations in triple-negative myeloproliferative neoplasms. *Blood*. 2016;127(3):325-332.
24. Cabagnols X, Favale F, Pasquier F, et al. Presence of atypical thrombopoietin receptor (MPL) mutations in triple-negative essential thrombocythemia patients. *Blood*. 2016;127(3):333-342.
25. Malcovati L, Della Porta MG, Pietra D, et al. Molecular and clinical features of refractory anemia with ringed sideroblasts associated with marked thrombocytosis. *Blood*. 2009;114(17):3538-3545.
26. Malcovati L, Papaemmanuil E, Bowen DT, et al; Chronic Myeloid Disorders Working Group of the International Cancer Genome Consortium and of the Associazione Italiana per la Ricerca sul Cancro Gruppo Italiano Malattie Mieloproliferative. Clinical significance of SF3B1 mutations in myelodysplastic syndromes and myelodysplastic/myeloproliferative neoplasms. *Blood*. 2011;118(24):6239-6246.
27. Malcovati L, Karimi M, Papaemmanuil E, et al. SF3B1 mutation identifies a distinct subset of myelodysplastic syndrome with ring sideroblasts. *Blood*. 2015;126(2):233-241.
28. Cabagnols X, Cayuela JM, Vainchenker W. A CALR mutation preceding BCR-ABL1 in an atypical myeloproliferative neoplasm. *N Engl J Med*. 2015;372(7):688-690.
29. Bonzheim I, Mankel B, Klapthor P, et al. CALR-mutated essential thrombocythemia evolving to chronic myeloid leukemia with coexistent CALR mutation and BCR-ABL translocation. *Blood*. 2015;125(14):2309-2311.
30. Loghavi S, Pemmaraju N, Kanagal-Shamanna R, et al. Insights from response to tyrosine kinase inhibitor therapy in a rare myeloproliferative neoplasm with CALR mutation and BCR-ABL1. *Blood*. 2015;125(21):3360-3363.
31. Passamonti F, Rumi E, Pietra D, et al. Relation between JAK2 (V617F) mutation status, granulocyte activation, and constitutive mobilization of CD34+ cells into peripheral blood in myeloproliferative disorders. *Blood*. 2006;107(9):3676-3682.
32. McMullin MF, Reilly JT, Campbell P, et al; National Cancer Research Institute, Myeloproliferative Disorder Subgroup; British Committee for Standards in Haematology. Amendment to the guideline for diagnosis and investigation of polycythaemia/erythrocytosis. *Br J Haematol*. 2007;138(6):821-822.
33. Hultcrantz M, Kristinsson SY, Andersson TM, et al. Patterns of survival among patients with myeloproliferative neoplasms diagnosed in Sweden from 1973 to 2008: a population-based study. *J Clin Oncol*. 2012;30(24):2995-3001.
34. Rumi E, Passamonti F, Della Porta MG, et al. Familial chronic myeloproliferative disorders: clinical phenotype and evidence of disease anticipation. *J Clin Oncol*. 2007;25(35):5630-5635.
35. Rumi E, Harutyunyan AS, Pietra D, et al; Associazione Italiana per la Ricerca sul Cancro Gruppo Italiano Malattie Mieloproliferative Investigators. CALR exon 9 mutations are somatically acquired events in familial cases of essential thrombocythemia or primary myelofibrosis. *Blood*. 2014;123(15):2416-2419.
36. Passamonti F, Rumi E, Pungolino E, et al. Life expectancy and prognostic factors for survival in patients with polycythemia vera and essential thrombocythemia. *Am J Med*. 2004;117(10):755-761.
37. Pietra D, Rumi E, Ferretti VV, et al. Differential clinical effects of different mutation subtypes in CALR-mutant myeloproliferative neoplasms. *Leukemia*. 2016;30(2):431-438.
38. Barbui T, Barosi G, Birgegard G, et al; European LeukemiaNet. Philadelphia-negative classical myeloproliferative neoplasms: critical concepts and management recommendations from European LeukemiaNet. *J Clin Oncol*. 2011;29(6):761-770.
39. Alvarez-Larrán A, Cervantes F, Pereira A, et al. Observation versus antiplatelet therapy as primary prophylaxis for thrombosis in low-risk essential thrombocythemia. *Blood*. 2010;116(8):1205-1210, quiz 1387.
40. Finazzi G, Carobbio A, Guglielmelli P, et al. Calreticulin mutation does not modify the IPSET score for predicting the risk of thrombosis among 1150 patients with essential thrombocythemia. *Blood*. 2014;124(16):2611-2612.
41. Barbui T, Vannucchi AM, Buxhofer-Ausch V, et al. Practice-relevant revision of IPSET-thrombosis based on 1019 patients with WHO-defined essential thrombocythemia. *Blood Cancer J*. 2015;5:e369.
42. Alvarez-Larrán A, Pereira A, Guglielmelli P, et al. Antiplatelet therapy versus observation in low-risk essential thrombocythemia with a CALR mutation. *Haematologica*. 2016;101(8):926-931.
43. Pascale S, Petrucci G, Dragani A, et al. Aspirin-insensitive thromboxane biosynthesis in essential thrombocythemia is explained by accelerated renewal of the drug target. *Blood*. 2012;119(15):3595-3603.
44. Ruggeri M, Finazzi G, Tosi A, Riva S, Rodeghiero F, Barbui T. No treatment for low-risk thrombocythaemia: results from a prospective study. *Br J Haematol*. 1998;103(3):772-777.
45. Cortelazzo S, Finazzi G, Ruggeri M, et al. Hydroxyurea for patients with essential thrombocythemia and a high risk of thrombosis. *N Engl J Med*. 1995;332(17):1132-1136.
46. Barbui T, Finazzi G. When and how to treat essential thrombocythemia. *N Engl J Med*. 2005;353(1):85-86.
47. Carobbio A, Antonioli E, Guglielmelli P, et al. Leukocytosis and risk stratification assessment in essential thrombocythemia. *J Clin Oncol*. 2008;26(16):2732-2736.
48. Carobbio A, Finazzi G, Antonioli E, et al. Hydroxyurea in essential thrombocythemia: rate and clinical relevance of responses by European LeukemiaNet criteria. *Blood*. 2010;116(7):1051-1055.
49. Carobbio A, Thiele J, Passamonti F, et al. Risk factors for arterial and venous thrombosis in WHO-defined essential thrombocythemia: an international study of 891 patients. *Blood*. 2011;117(22):5857-5859.
50. Campbell PJ, MacLean C, Beer PA, et al. Correlation of blood counts with vascular complications in essential thrombocythemia: analysis of the prospective PT1 cohort. *Blood*. 2012;120(7):1409-1411.
51. Björkholm M, Derolf AR, Hultcrantz M, et al. Treatment-related risk factors for transformation to acute myeloid leukemia and myelodysplastic syndromes in myeloproliferative neoplasms. *J Clin Oncol*. 2011;29(17):2410-2415.
52. Antonioli E, Guglielmelli P, Pieri L, et al; AGIMM Investigators. Hydroxyurea-related toxicity in 3,411 patients with Ph⁻-negative MPN. *Am J Hematol*. 2012;87(5):552-554.
53. Quintás-Cardama A, Kantarjian H, Manshouri T, et al. Pegylated interferon alfa-2a yields high rates of hematologic and molecular response in patients with advanced essential thrombocythemia and polycythemia vera. *J Clin Oncol*. 2009;27(32):5418-5424.
54. Quintás-Cardama A, Abdel-Wahab O, Manshouri T, et al. Molecular analysis of patients with polycythemia vera or essential thrombocythemia receiving pegylated interferon α -2a. *Blood*. 2013;122(6):893-901.
55. Cassinat B, Verger E, Kiladjian JJ. Interferon alfa therapy in CALR-mutated essential thrombocythemia. *N Engl J Med*. 2014;371(2):188-189.
56. Kiladjian JJ, Giraudier S, Cassinat B. Interferon-alpha for the therapy of myeloproliferative neoplasms: targeting the malignant clone. *Leukemia*. 2016;30(4):776-781.
57. Sleijfer S, Bannink M, Van Gool AR, Kruit WH, Stoter G. Side effects of interferon-alpha therapy. *Pharm World Sci*. 2005;27(6):423-431.
58. Kiladjian JJ, Mesa RA, Hoffman R. The renaissance of interferon therapy for the treatment of myeloid malignancies. *Blood*. 2011;117(18):4706-4715.
59. Harrison CN, Campbell PJ, Buck G, et al; United Kingdom Medical Research Council Primary Thrombocythemia 1 Study. Hydroxyurea compared with anagrelide in high-risk essential thrombocythemia. *N Engl J Med*. 2005;353(1):33-45.
60. Barosi G, Besses C, Birgegard G, et al. A unified definition of clinical resistance/intolerance to hydroxyurea in essential thrombocythemia: results of a consensus process by an international working group. *Leukemia*. 2007;21(2):277-280.
61. Gugliotta L, Besses C, Griesshammer M, et al. Combination therapy of hydroxycarbamide with anagrelide in patients with essential thrombocythemia in the evaluation of Xagrid(R) efficacy and long-term safety study. *Haematologica*. 2014;99(4):679-687.
62. Alvarez-Larrán A, Martínez-Avilés L, Hernández-Boluda JC, et al. Busulfan in patients with polycythemia vera or essential thrombocythemia refractory or intolerant to hydroxyurea. *Ann Hematol*. 2014;93(12):2037-2043.
63. Wiestner A, Schlemper RJ, van der Maas AP, Skoda RC. An activating splice donor mutation in the thrombopoietin gene causes hereditary thrombocythaemia. *Nat Genet*. 1998;18(1):49-52.
64. Ghilardi N, Skoda RC. A single-base deletion in the thrombopoietin (TPO) gene causes familial essential thrombocythemia through a mechanism of more efficient translation of TPO mRNA. *Blood*. 1999;94(4):1480-1482.
65. Ding J, Komatsu H, Wakita A, et al. Familial essential thrombocythemia associated with a dominant-positive activating mutation of the c-MPL gene, which encodes for the receptor for thrombopoietin. *Blood*. 2004;103(11):4198-4200.
66. Mead AJ, Rugless MJ, Jacobsen SE, Schuh A. Germline JAK2 mutation in a family with hereditary thrombocytosis. *N Engl J Med*. 2012;366(10):967-969.
67. Rumi E, Harutyunyan AS, Casetti I, et al. A novel germline JAK2 mutation in familial myeloproliferative neoplasms. *Am J Hematol*. 2014;89(1):117-118.
68. Etheridge SL, Cosgrove ME, Sangkhae V, et al. A novel activating, germline JAK2 mutation, JAK2R564Q, causes familial essential thrombocytosis. *Blood*. 2014;123(7):1059-1068.

69. Marty C, Saint-Martin C, Pecquet C, et al. Germ-line JAK2 mutations in the kinase domain are responsible for hereditary thrombocytosis and are resistant to JAK2 and HSP90 inhibitors. *Blood*. 2014;123(9):1372-1383.
70. Rumi E, Passamonti F, Pietra D, et al. JAK2 (V617F) as an acquired somatic mutation and a secondary genetic event associated with disease progression in familial myeloproliferative disorders. *Cancer*. 2006;107(9):2206-2211.
71. Bellanné-Chantelot C, Chaumarel I, Labopin M, et al. Genetic and clinical implications of the Val617Phe JAK2 mutation in 72 families with myeloproliferative disorders. *Blood*. 2006;108(1):346-352.
72. Hultcrantz M, Lund SH, Landgren O, et al. Survival in patients with familial and sporadic myeloproliferative neoplasms. *Blood*. 2015;125(23):3665-3666.
73. Harrison C. Pregnancy and its management in the Philadelphia negative myeloproliferative diseases. *Br J Haematol*. 2005;129(3):293-306.
74. Passamonti F, Randi ML, Rumi E, et al. Increased risk of pregnancy complications in patients with essential thrombocythemia carrying the JAK2 (617V>F) mutation. *Blood*. 2007;110(2):485-489.
75. Melillo L, Tieghi A, Candoni A, et al. Outcome of 122 pregnancies in essential thrombocythemia patients: A report from the Italian registry. *Am J Hematol*. 2009;84(10):636-640.
76. Gangat N, Wolanskyj AP, Schwager S, Tefferi A. Predictors of pregnancy outcome in essential thrombocythemia: a single institution study of 63 pregnancies. *Eur J Haematol*. 2009;82(5):350-353.
77. Passamonti F, Rumi E, Randi ML, Morra E, Cazzola M. Aspirin in pregnant patients with essential thrombocythemia: a retrospective analysis of 129 pregnancies. *J Thromb Haemost*. 2010;8(2):411-413.
78. Xu TT, Zhou F, Deng CY, Huang GQ, Li JK, Wang XD. Low-dose aspirin for preventing preeclampsia and its complications: a meta-analysis. *J Clin Hypertens (Greenwich)*. 2015;17(7):567-573.
79. Randi ML, Bertozzi I, Rumi E, et al. Pregnancy complications predict thrombotic events in young women with essential thrombocythemia. *Am J Hematol*. 2014;89(3):306-309.
80. Chait Y, Condat B, Cazals-Hatem D, et al. Relevance of the criteria commonly used to diagnose myeloproliferative disorder in patients with splanchnic vein thrombosis. *Br J Haematol*. 2005;129(4):553-560.
81. Dentali F, Squizzato A, Brivio L, et al. JAK2V617F mutation for the early diagnosis of Ph-myeloproliferative neoplasms in patients with venous thromboembolism: a meta-analysis. *Blood*. 2009;113(22):5617-5623.
82. Roques M, Park JH, Minello A, Bastie JN, Girodon F. Detection of the CALR mutation in the diagnosis of splanchnic vein thrombosis. *Br J Haematol*. 2015;169(4):601-603.
83. De Stefano V, Ruggeri M, Cervantes F, et al. High rate of recurrent venous thromboembolism in patients with myeloproliferative neoplasms and effect of prophylaxis with vitamin K antagonists [published online ahead of print May 13, 2016]. *Leukemia*.
84. Verstovsek S, Passamonti F, Rambaldi A, et al. Long-term results from a phase II open-label study of ruxolitinib in patients with essential thrombocythemia refractory to or intolerant of hydroxyurea [abstract]. *Blood*. 2014;124(21):Abstract 1847.
85. Pieri L, Pancrazzi A, Pacilli A, et al. JAK2V617F complete molecular remission in polycythemia vera/essential thrombocythemia patients treated with ruxolitinib. *Blood*. 2015;125(21):3352-3353.
86. Baerlocher GM, Oppliger Leibundgut E, Ottmann OG, et al. Telomerase inhibitor imetelstat in patients with essential thrombocythemia. *N Engl J Med*. 2015;373(10):920-928.
87. Armanios M, Greider CW. Treating myeloproliferation—on target or off? *N Engl J Med*. 2015;373(10):965-966.
88. Gisslinger H, Zagrijtschuk O, Buxhofer-Ausch V, et al. Ropgeinterferon alfa-2b, a novel IFN α -2b, induces high response rates with low toxicity in patients with polycythemia vera. *Blood*. 2015;126(15):1762-1769.